



REDUCES YOUR CHANCES OF MADIOCRITY



HARDCORE
FRAMES.
SHEETMETAL.
SPRINGERS.

WWW.THOMPSONCHOPPERS.COM

THOMPSON CHOPPERS



FEW CAN COMPARE. THOMPSON CHOPPERS COMBINES WORLD-CLASS ENGINEERING AND SKILLED CRAFTSMANSHIP TO PRODUCE EXOTIC HAND-BUILT MOTORCYCLES, FRAMES, SPRINGERS AND COMPONENTS FOR THOSE WHO ARE NOT AFRAID TO PUSH THE LIMITS OF STYLE, QUALITY AND PERFORMANCE.



WE USE ONLY THE HIGHEST QUALITY MATERIALS AND COMPONENTS AND EMPLOY PRECISE, TIME TESTED FABRICATING METHODS IN OUR CONTINUING PURSUIT TO REVOLUTIONIZE MOTORCYCLE DESIGN AND CONSTRUCTION. WHETHER YOUR PASSION IS RIDING, BUILDING, OR BOTH, YOU CAN RELY ON THOMPSON CHOPPERS TO DELIVER A FIRST-RATE EXPERIENCE.



OUR HOME IN SPRINGFIELD, MISSOURI IS A REGION LONG NOTED FOR EXCELLENT CRAFTSMANSHIP AND MECHANICAL INNOVATION. AS ONE OF THE ONLY MOTORCYCLE FABRICATORS THAT ENGINEER AND MANUFACTURE OUR OWN COMPONENTS, WE ARE PROUD TO BE TAKING MOTORCYCLES IN A BOLD, NEW DIRECTION.

STOP FANTASIZING.
MOW DOWN THE MASSES
WITH A CUSTOM FROM
THOMPSON CHOPPERS.



SPRINGER FRONTENDS

the EXECUTIONER

Handcrafted from the finest materials, CNC precision cut and TIG welded. Featuring large 1.75" back legs and 1.5" front legs for a massive look, the Executioner Wide Glide Springer frontend enables you to hurdle the wounded and trample the dead with a bulletproof ride. Every springer is custom built to order and calculated to give the best trail for your ride.



MEASUREMENTS

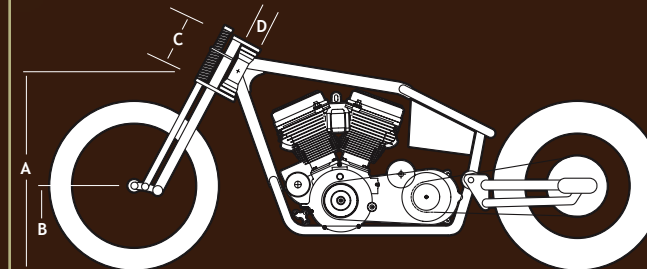

NOTE: Position the frame level and set to final ride height with rear wheel in place to ensure a proper fit

- A: Measure from ground to the center of the neck
- B: Measure from ground to center of front axle
- C: Measure neck length including cups & bearings
- D: Measure rake of neck in degrees

FINISH OPTIONS

Powder Coating or Paint Chrome Plating

Trying to match your frontend to your frame? Let us provide the exact match. Our springers can be delivered color matched in either powder coat or epoxy paint.

Need a little bling? Let us take the hassle out of the plating process. Our frontends can be delivered professionally polished and plated in chrome or nickel.



RIGID & SOFTAIL FRAMES

CRIME SCENE

HITMAN

WARLORD

TOMMY GUN

OUTLAW

The FELON

GANGSTER

FULL CLIP

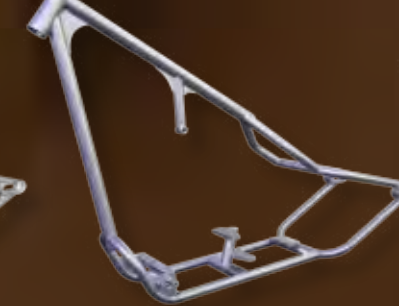

Frame Style: Pro-Street
Frame Type: Rigid or Softail
Tire Sizes: 250 thru 360
Motor Type: EVO or Twin Cam B

Frame Style: Bobber
Frame Type: Rigid
Tire Sizes: 180 thru 250
Motor Type: EVO or Twin Cam B

Frame Style: Hidden Shock
Frame Type: Softail
Tire Sizes: 180 thru 360
Motor Type: EVO

Frame Style: Chopper
Frame Type: Rigid or Softail
Tire Sizes: 180 thru 360
Motor Type: EVO or Twin Cam B

Frame Style: Chopper
Frame Type: Rigid or Softail
Tire Sizes: 180 thru 360
Motor Type: EVO or Twin Cam B

Frame Style: Chopper
Frame Type: Rigid or Softail
Tire Sizes: 180 thru 360
Motor Type: EVO or Twin Cam B

Frame Style: Sportster
Frame Type: Rigid or Softail
Tire Sizes: 180 thru 250
Motor Type: EVO or Ironhead

Frame Style: Fat Ass
Frame Type: Rigid or Softail
Tire Sizes: 330 thru 360
Motor Type: EVO

Available Specs

Available Specs

Available Specs

Available Specs

Available Specs

Available Specs

Available Specs

Available Specs

Option No. 1
Down-Tube Stretch: -2"
Backbone Stretch: 8"
Rake: 45°

Option No. 1
Down-Tube Stretch: 0"
Backbone Stretch: 0"
Rake: 30°

Option No. 1
Down-Tube Stretch: 0"
Backbone Stretch: 0"
Rake: 32°

Option No. 1
Down-Tube Stretch: 3"
Backbone Stretch: 5"
Rake: 40°

Option No. 1
Down-Tube Stretch: 6"
Backbone Stretch: 8"
Rake: 42°

Option No. 1
Down-Tube Stretch: 8"
Backbone Stretch: 10"
Rake: 42°

Option No. 1
Down-Tube Stretch: 0"
Backbone Stretch: 0"
Rake: 32°

Option No. 1
Down-Tube Stretch: -2"
Backbone Stretch: 8"
Rake: 45°

Option No. 2
Down-Tube Stretch: 0"
Backbone Stretch: 6"
Rake: 42°

Option No. 2
Down-Tube Stretch: 1"
Backbone Stretch: 2"
Rake: 32°

Option No. 2
Down-Tube Stretch: 2"
Backbone Stretch: 4"
Rake: 38°

Option No. 2
Down-Tube Stretch: 6"
Backbone Stretch: 4"
Rake: 42°

Option No. 2
Down-Tube Stretch: 8"
Backbone Stretch: 8"
Rake: 45°

Option No. 2
Down-Tube Stretch: 10"
Backbone Stretch: 12"
Rake: 45°

Option No. 2
Down-Tube Stretch: 2"
Backbone Stretch: 4"
Rake: 38°

Option No. 2
Down-Tube Stretch: 3"
Backbone Stretch: 5"
Rake: 40°

Option No. 3
Down-Tube Stretch: 2"
Backbone Stretch: 8"
Rake: 45°

Option No. 3
Down-Tube Stretch: 0"
Backbone Stretch: 4"
Rake: 32°

Option No. 3
Down-Tube Stretch: 6"
Backbone Stretch: 4"
Rake: 42°

Option No. 3
Down-Tube Stretch: 6"
Backbone Stretch: 4"
Rake: 42°

Option No. 3
Down-Tube Stretch: 6"
Backbone Stretch: 4"
Rake: 42°

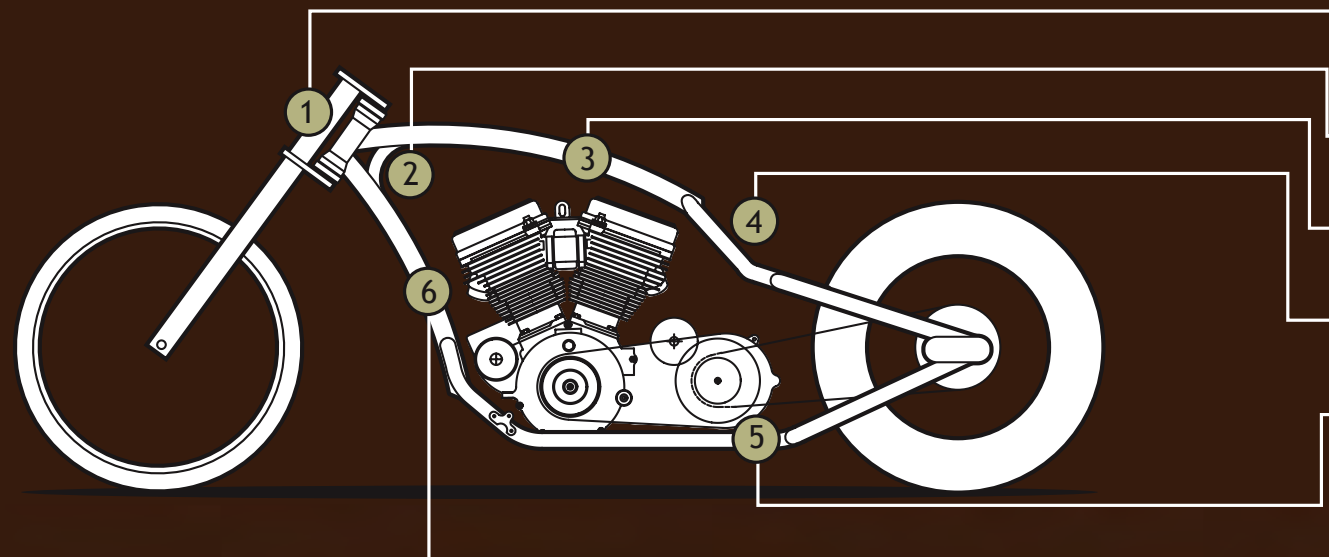

- (1) Custom Stretch and Neck Rake
- (2) Custom Designed Neck Gussets
- (3) Radiused / Curved Backbones
- (4) Dropped or Straight Seat Rails
- (5) Rear Frame Stretch for Longer Reach
- (6) Curved Downtube - Single or Double

ADDITIONAL FRAME OPTIONS

Needing to spec your own frame? For a small additional set-up fee, you can pick your own stretch, rake and tire size, and we'll do the rest. You also have many other options to choose from, including drop seats, curved back-bone, double down tube, and right or left hand drive, among others.

FENDER BLANKS

Rear Fender Blanks

Wheel Size	Tire Size	Width
18" Fender	190-200	9 1/4"
18" Fender	230-240	10 1/2"
18" Fender	240-250	11"
18" Fender	250-280	12 1/2"
18" Fender	300	13 1/4"
18" Fender	360	15 1/4"

Front Fender Blanks

Wheel Size	Diameter	Width
21" Fender	28 3/4"	5 3/8"
21" Fender	28 3/4"	4 3/8"
19" Fender	28"	5 1/8"
19" Fender	28"	4 7/8"

Our fender blanks are constructed from 11 gauge cold rolled steel and TIG welded. Each blank is a full 180° with a minimum of 6" sidewall.

Custom shaping, cutting and mounting is also available. Ask for details.

GAS TANKS

Our tanks are handcrafted from 14 gauge cold rolled steel and TIG welded. Each tank is pressure tested. Each tank is custom built to order and can be built narrow or wide, short or long.

Each tank includes pop-up cap with center, right or dual fill. Standard tunnel width is 2 1/4". Tunnels can be adjusted to sit high or low on your frame.

Each tank has 4 threaded mounts and 2 crossover fittings, as well as a threaded petcock fitting.

OIL TANKS

Whether your needs are for the look of a stock replacement, or one of our built-in, concealed "Whiskey Flask" oil tanks, we can help. You have several options to choose from, each with its unique advantages to fit the style you're going after. Either built-in or bolt on, each of our oil tanks is hand built out of 14 gauge cold rolled steel and pressure tested to assure a lifetime of service.

Most of our oil tanks are available with side fill or top fill, with your choice of with or without built-in battery box.



To build a great custom bike you need a great foundation. Let us take the guess work out of your next build. Thompson Choppers offers a variety of rolling chassis kits designed in various stages to fit your needs. We have carefully selected complementary components as the starting point for our rollers. From basic to almost finished, we offer many options and specs. Just call or email for details.

Stage One Roller (Built to Your Specs)

Frame: Rigid or Softail
 Tire Size: 180 thru 360
 Rim Options: 60 Spoke or Billet
 Frontend Options: . . . Springer or 57mm Inverted

Stage Two Roller (Built to Your Specs)

Frame: Rigid or Softail
 Tire Size: 180 thru 360
 Rim Options: 60 Spoke or Billet
 Frontend Options: . . . Springer or 57mm Inverted
 Gas Tank: 4.5 Gal Teardrop / 12ga.
 Oil Tank: Round or Horseshoe

Stage Three Roller (Built to Your Specs)

Frame: Rigid or Softail
 Tire Size: 180 thru 360
 Rim Options: 60 Spoke or Billet
 Frontend Options: . . . Springer or 57mm Inverted
 Gas Tank: 4.5 Gal Teardrop / 12ga.
 Oil Tank: Round or Horseshoe
 Fenders: Front & Rear Blanks
 Handlebars: Flying "V"



NEED MORE INFORMATION?



ARE YOU LOOKING FOR ADVICE? DO YOU HAVE QUESTIONS ABOUT ANY OF OUR PRODUCTS? WE'LL BE MORE THAN HAPPY TO HELP.



PHONE: 417-864-7242
FAX: 800-854-1537



404 WEST WALNUT - BLDG. #A
SPRINGFIELD, MO 65806



WWW.THOMPSONCHOPPERS.COM
EMAIL: INFO@THOMPSONCHOPPERS.COM